

*la Solare*



**GAGGIA**  
MILANO

**LIGHT UP YOUR BREAK**

**GAGGIA**  
MILANO

# LIGHT UP YOUR BREAK!

La Solare is the new, fully automatic coffee machine by Gaggia Milano. It is the culmination of a series of cutting-edge technological advances, designed to enhance one of the most important rituals of the day: the coffee break.



## SYNONYMOUS WITH INNOVATION

With La Solare, you can offer customers beverages that combine the flavour of freshly ground coffee beans with the creaminess of fresh milk.

It's the perfect machine for all kinds of locations, from cafés to pastry shops; in retail or in hospitality.

In short, as we say in Italy, *La Solare ha tutto!*  
*It's got the lot...*

**REFINED  
PROFILES**

**A USER-FRIENDLY  
EXPERIENCE**

**YOUR BREAK  
IN FULL SAFETY**

**AN ENHANCED  
MILK SYSTEM**

**THE NEW Z4000 iX  
COFFEE GROUP**







## **THE STORY OF ONE OF THE WORLD'S MOST ICONIC ITALIAN BRANDS BEGAN IN 1930's MILAN.**

In 1938, barista Achille Gaggia filed the patent that signalled a revolution in the way aromas are extracted from coffee. Gaggia had created, for the very first time, the perfect Italian espresso - complete with its characteristic 'crema'.

Gaggia's mission today is the same as it's always been: to share authentic Italian espresso with the world. The company's intrinsic values of tradition and professionalism are self-evident throughout its product range, which has been designed to meet the requirements of coffee professionals by combining state-of-the-art technology with sophisticated design.



## REFINED PROFILES

The elegance of an iconic brand like Gaggia Milano is self-evident in the refined lines that characterize the design of La Solare. Its aluminium profiles with their inherent sparkle, the LED-illuminated dispensing area and the gleaming stainless-steel components are just some of the features of La Solare demonstrating the attention to detail that has been lavished on this machine ever since the design stage.



## A USER-FRIENDLY EXPERIENCE

We've used the same meticulous attention to detail to ensure that La Solare is intuitive and easy to use. In fact, in self-service mode, which is accessible via the [7-inch touchscreen](#), customers can easily select and customize their own drinks.





# YOUR BREAK IN FULL SAFETY

To ensure the safety of both operators and consumers, 'hygiene' is a top-priority with La Solare. Every aspect of the machine, its technologies and its design, have been scrutinised to ensure compliance with all current safety regulations.



Thanks to the presence of silver ions, the **Pure Zone® adhesive film** shields the touchscreen of La Solare, blocking microbial proliferation 24/7 - for up to 5 years. Pure Zone® is waterproof, compatible with all cleaning protocols and resistant to all leading cleaning and sanitizing products.



**Coffee APPeal®** is the free mobile selection app which lets customers enjoy a touchless experience. Just scan the QR Code on the La Solare touchscreen and select your drink. You don't have to enter any personal information; you don't have to touch the machine.



## AN ENHANCED MILK SYSTEM

La Solare has been designed to deliver high-quality, **hot foamed milk-based beverages**, time after time, year after year. What's more, its innovative on-board milk technology offers a couple of great advantages, for consumers and unskilled personnel alike.



First of all, thanks to the software, also accessible via the 7-inch touchscreen, it is possible to **adjust and customize the amount of foam** specified in individual recipes.



Secondly, La Solare is equipped with programmable fully-automated cleaning cycles, which can be set up directly from the touchscreen. Also, as far as the the daily procedure required at the end of the service is concerned, **there's no need to disassemble any of its frother parts, nor to do any manual cleaning.** In this way, optimum standards of hygiene and cleanliness are always guaranteed.

## THE NEW Z4000 iX COFFEE GROUP

Z4000 iX is the innovative technology that further enhances the high-performing coffee technology that's part and parcel of Gaggia Milano's entire range of fully automatic machines.



Z4000 iX is a new brewing group, which boasts a **heated stainless-steel chamber** that ensures better stability, in terms of both temperature and quality perception.

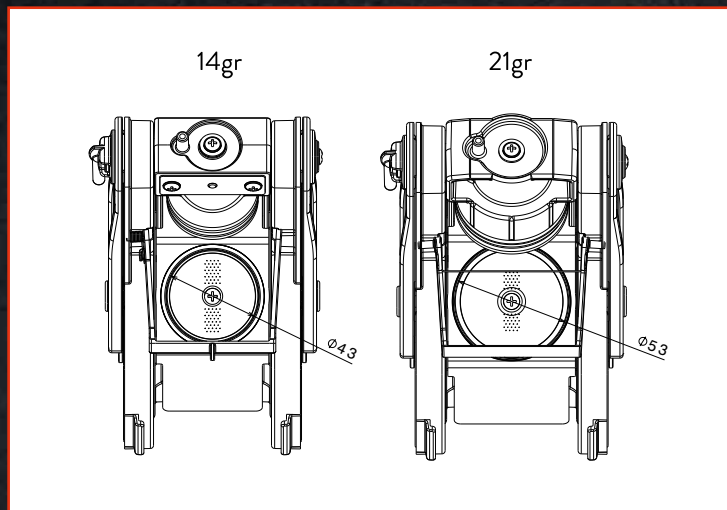

This means that the impressive drink quality offered by La Solare remains consistent, from the first coffee of the day to the last. Available in a double version, up to 14 or 21 grams to meet the needs of international markets, the innovative Z4000 iX coffee group also allows you to offer **a wider selection of drinks on your menu.**

# DIMENSIONS & WEIGHT





# la Solare

**TIMELESS**  
**DESIGN MEETS**  
**INNOVATION**  
**AND EFFICIENCY**

## DATA SHEET

### POWER SUPPLY

Voltage	230-240 V
Frequency	50-60 Hz
Maximum absorbed power	3200 W

### TECHNICAL FEATURES

LED-illuminated delivery area  
Manually adjustable nozzle from 72 to 169 mm  
Lateral hot water wand  
Double nozzle for both coffee and milk dispensing  
Programmable and Plug&Play cleaning cycles of the milk circuit  
7-inch touchscreen  
Up to 5 drink categories  
Up to 10 selections per each page  
Customisable User Interface: drink icons and background  
Customisable access to programming  
User interface in Self-service mode  
Energy-saving: Soft and Deep modes  
Integrated Wi-Fi and Bluetooth connectivity  
Compatible with telemetry platform Coffeed  
USB port

### CAPACITY

Coffee bean hopper(s) capacity	1,2 kg
Solubles hopper(s) capacity	1,5 lt
Z4000 iX coffee brewer capacity	Up to 14 or 21 gr <sup>(1)</sup>
Number of coffee grinders	1 or 2
Hot water and steam boiler capacity	0,8 lt (x2)
Suggested daily output	200 cups

### OPTIONAL

Self-adjusting grinding <sup>(2)</sup>  
Cool Touch steam wand <sup>(2)</sup>  
Ambient temperature water dispensing for iced drinks <sup>(2)</sup>  
4G connectivity kit

### ACCESSORIES

Trolley wood base cabinets  
From 4,5 to 7 Lt capable fridges, with possibility to have also the cup warmer  
Kit to install the fridge on the left  
Coffee cakes waste disposal kit  
Self-feeding water kit  
Milk circuit cleaning tablets  
Coffee brewer cleaning tablets

<sup>(1)</sup> Capacity depending on the coffee blend and granulometry. <sup>(2)</sup> Only available on specific version.

L513U0

EVOCA S.p.A. - Via Roma, 24 - 24030, Valbrembo, Bergamo - Italy  
Ph: (+39) 035 606 111 - Fax: (+39) 035 606 560

In accordance with its policy of progressive product design, EVOCA S.p.A. reserves the right to alter specifications.  
Gaggia is a trademark licensed by Gaggia S.p.A.

**GAGGIA**  
MILANO

AUTOMATEN SERVICE LÜBECK  
Gesellschaft für Automatenverpflegung mbH  
Lübeck - Schwerin - Hamburg - Kiel



www.asl-luebeck.de  
Heiß-/Kalt-, Snackautomaten  
Produkthandel und Service  
Reepschlägerstraße 11 a, 23556 Lübeck  
Tel. 0451/880 48 80 • Fax 880 48 81

WWW.GAGGIAPROFESSIONAL.COM

